

WD-7 DUPLUS GLASS

HOOD TYPE DISHWASHER

FEATURES

- The unique GLASS-LIFT prevents water from accumulating on the base of the glass. Manual polishing of glass is minimized
- Double final rinse with DUPLUS technology – Improved rinsing results using less fresh water
- High efficiency with low operating costs – DUPLUS technology reduces the consumption of fresh water, chemicals and electricity
- Unique and flexible washing system. The machines water pressure can be reset quickly and easily between normal and heavily soiled settings
- Robust and reliable design in stainless steel with components that guarantee a durable and reliable operation for many years
- The machine has an energy saving heat and sound insulating double-skinned hood
- A good working environment with the unique hood concept
- Detergent pump for liquid detergent
- High levels of hygiene with an automatic cleaning programme and guaranteed rinse temperature by thermal stop system
- Self-drained wash pump
- Large deep tank to protect against foaming
- Easy servicing - the machine is serviced from the front
- Hygiene control – control system with integrated HACCP
- Excellent wash results – with selfdraining washing arms
- Powerful washing pressure with anti-blocking nozzles
- Individual adjustable wash- and rinse times as well as temperatures for each programme
- Inbuilt dosing pump for fine dosage of rinse aid
- Break tank with booster pump
- Automatic cleaning program
- Water connection x 2 (RO)



OPTIONS

- Automatic hood
- Autostart for automatic hood
- 230V/3/50Hz
- Drain pump
- ECO-FLOW condensing unit with heat recovery by the exhausted steam. (cold water connection is required)
- WEB Tool - For external HACCP documentation

EXTRA EQUIPMENT

- Steam hood with suction connection
- Shelf for chemical storage
- Sideboard (560 x 560 mm)

TECHNICAL DATA	WD-7 DUPLUS GLASS
Wash pump (kW)	1.1
Pump, recirculated rinse (kW)	0.67
Pump, final rinse (kW)	0.67
Booster heater (kW)	9
Tank heater (kW)	5.4
Tank volume, chemical wash tank (liter)	45
Tank volume, recirculated rinse (liter)	5.5
Weight, machine in operation (kg)	195
Enclosure class (IP)	45

CAPACITY AND OPERATING DATA	WD-7 DUPLUS GLASS
Total washing time P1 (min) *	1.2
Total washing time P2 (min) *	1.8
Total washing time P3 (min) *	3.3
Max. capacity, baskets/hour (no.)	50
Water consumption rinsing/programme (liter)	1.0 - 1.5
Energy consumption (% of connected power)	30 - 50%
Sound level (dB(A))**	63

* Factory setting. The washing time can be adjusted.

*** Measured 1 metre from the side of the machine.

CONNECTION, MACHINE	WD-7 DUPLUS GLASS
Total connected power (kW)	10.1
Main fuse 400 3N~ (A) *	16
Max. connection area 400V 3N~ (L1-L3,N,PE) Cu (mm ²) **	2.5

* Other voltage on request.

** Cable 3 m H07RN-F is included.

WATER, DRAIN AND VENTILATION CONNECTIONS	WD-7 DUPLUS GLASS
Water quality, hardness (°dH)	2 - 7
Water connection 5-65°C (external thread)*	R ½"
Drain connection, PP pipe (ø mm.)	50
Water capacity, pressure (kPa)	20
Water capacity, flow (litres/min)	5
Floor drain, capacity (litres/sec)	3
Heat load to the room (total, sensible, latent) (kW)	1.7 / 1.2 / 0.5

* When using cold water <55°C the filling time is longer.

SIZE AND WEIGHT FOR TRANSPORTATION	WD-7 DUPLUS GLASS
Size, LxWxH (mm.)*	765x805x1650
Weight (kg)*	160

* Packaging included

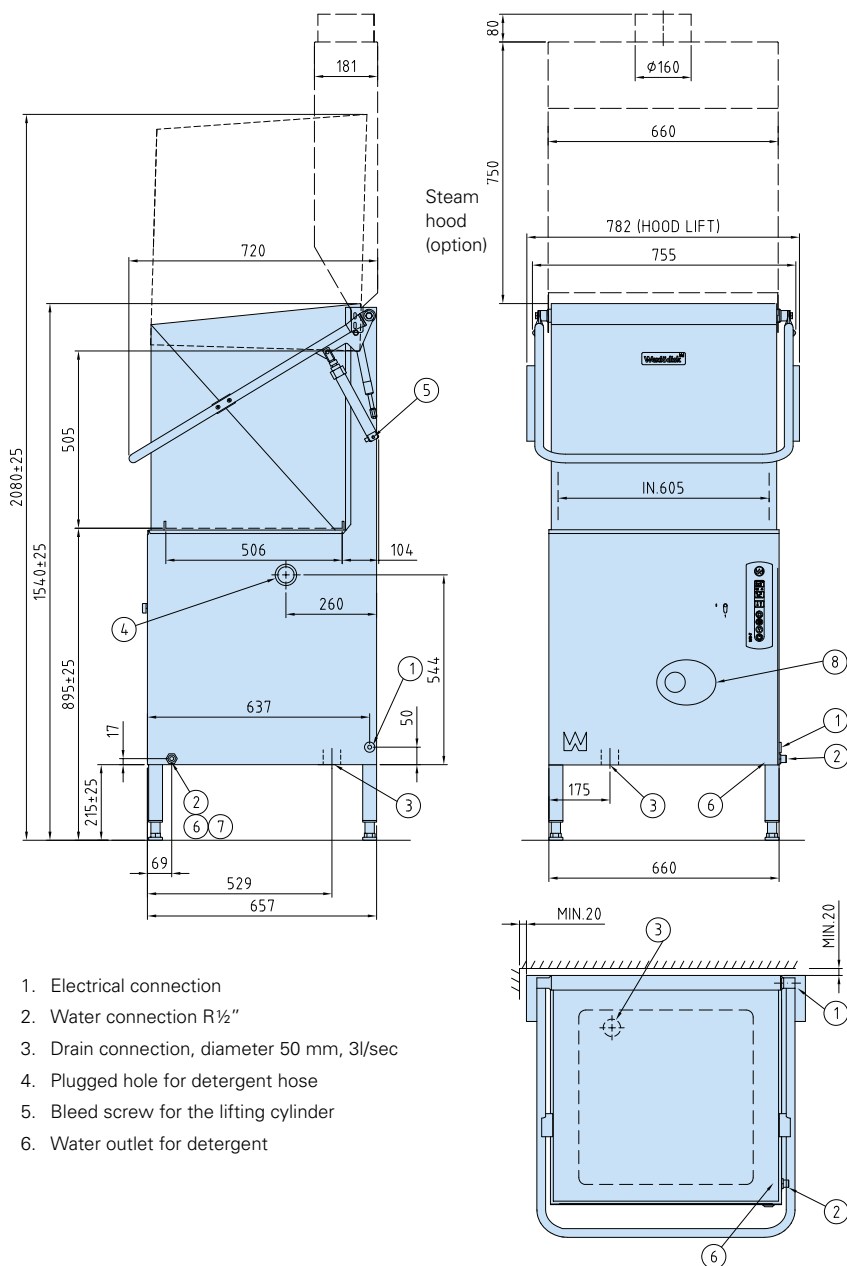

WD-7 DUPLUS GLASS with **ECO-FLOW** condensing unit and heat exchanger

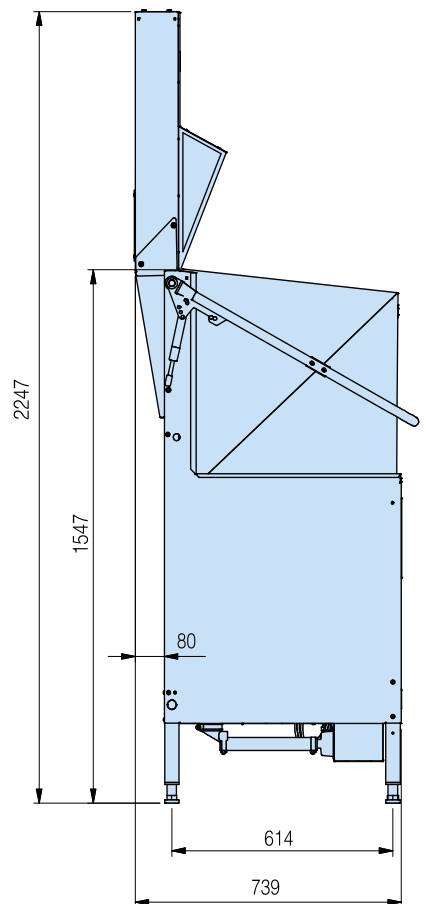

We reserve the right to change technical data.

Wexiödisk

TELEPHONE: +46 470 77 1200 FAX: +46 470 23752 ADDRESS: Mårdvägen 4 SE-352 45 Växjö SWEDEN
E-MAIL: wexiodisk@wexiodisk.com WEBB: www.wexiodisk.com